

3RP 5-BUTTON SERIES VEHICLE SECURITY SYSTEM WITH NETWORK INTERFACE

INSTALLATION MANUAL

Before you begin the installation

- Read the INSTRUCTIONS!
- Always use a multi-meter when verifying vehicle wiring.
- Before mounting the product, verify with the customer the desired location for the valet switch and LED.
- Protect the vehicle by using fender covers.
- Always look before drilling. Make sure you will not cause damage to vehicle hoses, electrical looms or physical damage to vehicle.
- Set the Polarity Jumpers inside the main unit. (see Jumper Settings)

Installation Instructions

Mounting System Module

Mount the system module under the dash where it will be difficult for a potential thief to locate the module, and away from moving parts such as brake pedals, etc.

Route the antenna wire away from wire looms, computer modules and metallic objects for better range.

Mounting Siren

Mount the siren in a suitable place under the hood, away from hot and moving engine parts such as manifolds, fan belts, etc. Make sure the siren cannot be accessed from underneath the vehicle or through the grill. Face the siren down so that water cannot accumulate inside the siren bell. Protect wires running through the firewall using either tape or split loom tubing. If a new hole is needed, protect the wire from chaffing by installing a proper size grommet.

Mounting Shock Sensor

Secure the shock sensor to the steering column, thick wire harness or a dash brace, using a wire tie. Make sure that the adjustment screw is accessible for later testing and adjustment.

Main Harness:

- **BROWN WIRE** - Siren wire output (+) 3A. Connect to the siren's red wire. Connect the siren's black wire to ground.
- **BLACK WIRE** - Ground input (-). Connect to a solid chassis ground that is clean and free of paint or dirt.
- **ORANGE WIRE** - Armed Output (-) 500mA. Connect to a relay for optional circuit defeat (See installation diagrams). The ORANGE wire provides a ground when the unit is armed to activate a fuel pump disable relay or other device (i.e. window control module, etc.).
- **BLUE/BLACK WIRE** - Optional sensor input (-). Connect this wire to the trigger output of an optional sensor.
- **YELLOW WIRE** - +12V Ignition input. Connect to a main ignition wire at the ignition switch harness. This wire shows +12V when the ignition is on and while cranking. The voltage must not drop when the car is starting.
- **BROWN/WHITE WIRE** - Horn output (-) 500mA. Connect to an optional relay to activate the vehicle's horn when the alarm is triggered.
- **BLACK/YELLOW WIRE** - Auxiliary 3 output (-) 500mA. Connect to a relay for an optional feature such as headlight activation, etc. This output may be programmed for momentary, timed, or latched operation.
- **GRAY WIRE** - Auxiliary 1 output (-) 500mA. Connect to a relay for optional features such as trunk release, etc. This output is programmable for momentary, timed, or latched operation.
- **WHITE WIRE** - Parking Light output (+/-) 10A relay. Connect to the vehicle's parking light wire. If the vehicle's parking light circuit exceeds 10 amps a relay is required. For vehicle's with independent left and right parking light circuits, the parking light wires must be connected using

diodes to keep the circuits separate. NOTE: Do not connect the WHITE wire to the vehicle's headlight circuit.

- **RED WIRE** - +12V Battery input. Connect the red fused wire on the main harness to a constant +12V source. This source wire should be at least 20 amp supply.
- **BLACK/WHITE WIRE** - Dome Light output (+/-) 15A relay. Connect to the wire that activates the vehicle's dome light, usually the door pin switch wire. NOTE: The dome light output is usually connected to the same wire used for the door trigger input (See GREEN and VIOLET door trigger wires).
- **BLUE/WHITE WIRE** - Passenger Unlock output (-) 500mA. Connect to an optional relay to unlock the passenger doors when the system is configured for Driver Priority Unlocking.
- **WHITE/RED WIRE** - Auxiliary 2 output (-) 500mA. Connect to a relay or module for an optional feature such as power window activation or remote start, etc. This output may be programmed for momentary, timed, or latched operation.
- **VIOLET WIRE** - Positive door trigger (+). Connect to the door switch circuit wire that shows +12V when the door is open. This type of door circuit is usually found on Ford vehicles.
- **GREEN WIRE** - Negative door trigger (-). Connect to the door switch circuit wire that shows ground when the door is open.
- **BLUE WIRE** - Trunk/Hood trigger (-). Connect the Blue wire to the trunk and/or optional hood pin switches. The switch must provide a ground output when switch is opened. If the optional remote start module is installed, connect the blue wire to the trunk pin switch only and connect the hood pin input on the remote start module to the hood pin switch only.

Starter Defeat Connectors

Using a volt/ohm meter locate the starter wire (normally a heavier gauge wire) at the ignition switch. This wire will show +12V only during cranking. When this wire is cut the vehicle will be unable to start.

Cut the BROWN starter disable wire (with the two female connectors), and connect one side to the vehicle's starter wire coming from the key switch. Connect the other BROWN wire to the wire going to the starter.

Plug the female connectors on the BROWN wires to the .250 male spade lugs on the module. With the BROWN wires connected to the module, the vehicle should be able to start.

Plug in Connectors

4-Pin White Connector: Plug-in connector port for dual stage shock sensor.

2-Pin Blue Connector: Plug-in connector port for valet switch. Mount valet switch in an area that is easily accessible from the driver's position.

2-Pin Red Connector: Plug-in connector port for LED. Mount LED in an area where it may be easily seen from either side of the vehicle.

3-Pin White Door Lock Connector: Plug-in connector port for door lock harness or optional door lock relay module (PDLM-3).

- BLUE WIRE - negative unlock output (-) 500mA and positive lock output (+) 250mA.

- RED WIRE - constant +12V low current output (+) for relay modules, or inverters. 300mA relay trigger only. Do NOT use as a power source for door lock relays.

- GREEN WIRE - negative lock output (-) 500mA and positive unlock output (-) 250mA.

3-Pin White Network Connector: The plug-in network connector port is located on the side

of the main module. This network port may be used with the optional personal computer interface for diagnostics, software customization and expanded programming options. The network also offers connection to several optional accessories.

Adding Transmitters

To add a new transmitter to the system have the desired transmitters ready and follow the Code Learning sequence.

To enter Code Learning Mode:

1. Turn the ignition on, off, on, off and leave on.
 - The siren will chirp 3 times.
2. Press and hold the Valet switch for 5 seconds.
 - The siren will chirp 5 times.
3. Press the Lock Button on the transmitter.
 - The siren will chirp once.
4. Press Lock Button on the transmitter again.
 - The siren will chirp twice.
5. Repeat steps 3 and 4 for each additional transmitter.
6. Turn off the ignition.
 - The siren will chirp 3 times.

Two Car Operation

With the supplied 5-button transmitter it is possible to control a second vehicle using the same primary transmitter. For Car 2 enter the Code Learning Mode as described above then substitute the steps below for 3 and 4..

3. Press Button 5 twice followed by the Lock Button.
 - The siren will chirp once.
4. Press Button 5 twice followed by the Lock Button.
 - The siren will chirp twice.

Entering Programming

To enter System Programming:

1. Turn on ignition.
2. Within 5 seconds, press valet switch 5 times.
 - The siren will chirp 3 times, indicating that you have entered Programming.
3. Press the valet switch the number times equal to the Feature you want to change.
 - The siren will chirp each time the valet switch is pressed.
4. Within 5 seconds, press the transmitter button corresponding to the desired operating mode for that Feature.
 - The siren will chirp to indicate the setting.
One chirp = Button 1
Two chirps = Button 2
Three chirps = Button 3
5. Repeat steps 3 and 4 to change additional features.
6. Turn off ignition to save changes.

Programmable Features

<u>Step</u>	<u>Function</u>	<u>Button 1</u>	<u>Button 2</u>	<u>Button 3</u>
1.	Arming Mode	Active	Passive	
2.	Auto Rearm	Off	On	
3.	Normal/Silent Arming	Normal	Silent	
4.	Ignition Locking	On	Off	Override Code Set
5.	Ignition Unlocking	All Doors	Driver only	Off
6.	Door Unlock Pulse	Single	Double	
7.	Door Lock Pulse Width	1 second	3 seconds	
8.	Passive Locking	Off	On	
9.	Entry Delay with Passive Arming	Off	On	
10.	Bad Zone Report	5 seconds	Off	
11.	Siren / Horn Chirps	Siren only	Horn chirps	
12.	Horn Honk / Alarming Output	Flashing	Continuous	
13.	Auxiliary 2 Auto Activate on Arming	Off	On	
14.	Auxiliary 1 Output	Momentary	Timed	Latched
15.	Auxiliary 2 Output	Momentary	Timed	Latched
16.	Auxiliary 3 Output	Momentary	Timed	Latched
17.	Trunk Disarm Feature	Off	On	
18.	Remote Start in Valet Mode (optional)	Enabled	Disabled	
19.	Start Module Program (optional)	Learn RPM	Gas	Diesel
20.	Automatic Starting (option)	Disabled	Temperature	Voltage
21.	FM Module Program (optional)	Learn Module	Learn Transmitter	

Programmable Features

1. Arming Mode. Select between manual arming (Active) or automatic arming (Passive).
2. Auto Rearm. Automatically rearms the system in case of accidental disarming. The system must be armed for at least 10 seconds before disarming, and the hood/trunk must not be opened or Auto Rearm will be bypassed.
3. Arming Chirps. Select Normal or Silent Arming.
4. Ignition Locking / Override Code Set. Automatically locks the doors when the ignition is turned on. The system will not lock the doors if any door is open when the ignition is turned on. Pressing Button 3 during this step enters the Override Code Set mode. Press the valet switch the desired number of times from 1-15 to set the code.
5. Ignition Unlocking. Automatically unlocks the doors when the ignition is turned off. Select from all door unlock, driver's door only unlock, or no unlock. (Note: Driver's door only unlock requires wiring the system for Passenger Unlock. see Two Step Unlocking Diagrams.)
6. Door Unlock Pulse - Single/Double. Selects between a single pulse or a double pulse door unlock output.
7. Door Lock Pulse Width. Selects between a 1-second and a 4-second output for vehicles equipped with vacuum door locking systems.
8. Passive Locking. Selects whether or not the system will automatically lock the doors with Auto Rearm and Passive Arming.
9. Door Entry Delay with Passive Arming. When selected, the door input trigger will be delayed for 15 seconds, allowing access to the emergency override switch. Only delays when the system is armed passively.

10. Bad Zone Report. Siren will chirp 3 times if any zone remains open 5 seconds after arming. If vehicle has delayed dome light, program this feature to OFF.

11. Siren / Horn Chirps. When set for Horn Chirps, the horn will honk when arming and disarming allowing the siren to NOT be installed.

12. Horn Honk / Arming Output. Selects between pulsed or constant output for the Brown/white wire.

13. Auxiliary 2 Auto Activate on Arming. When selected, the Auxiliary 2 output will pulse upon system arming to activate accessory items when the system is armed.

14. Auxiliary Function 1 - Selectable for Momentary, Timed, or Latched operation.

When Momentary operation is selected, the system will provide an output for as long as the Transmitter button is held.

When Latched operation is selected, the system will provide an output that turns on when the transmitter button is pressed and turns off when the transmitter button is pressed again.

When Timed operation is selected, the system will provide an output that turns on for 30 seconds each time the transmitter button is pressed. If the button is pressed again during the 30 seconds, the output will turn off.

15. Auxiliary Function 2 - Selectable for Momentary, Timed, or Latched operation.

16. Auxiliary Function 3 - Selectable for Momentary, Timed, Latched operation or Ignition Latched operation.

17. Trunk Disarm Feature. When selected, activating the Auxiliary 1 function to open the trunk will automatically disarm the system.

18. Remote Start in Valet Mode. Determines if the remote start feature will operate when the alarm is set for valet mode.

19. Program RPM. When the remote start is connected, pressing transmitter button 1 "learns" the RPM. Pressing button 2 or 3 sets the engine mode for gas or diesel.

20. Automatic Starting. Selects between off, low temperature starting, and low voltage starting.

21. FM Transmitter Module. Pressing button 1 learns the add-on FM module ID so the FM transmitter can operate the system. Pressing button 2 learns the FM transmitter. After pressing button 2 on the AM remote, press transmitter button 1 on each FM remote (max 2).

Complete Default Reset

Following this procedure will set all User and Installer Programming Parameters to factory default settings.

1. Enter System Programming.
2. Press Transmitter Button 3.
 - The siren will chirp 6 times indicating the reset signal was received.
 - All Installer and User Programming options are now set to factory default settings.
3. Turn ignition off.

Test System and Adjust Shock Sensor

Arm and disarm system, checking that the siren chirps and parking lights are functioning normally. Make sure that the programmed features are performing correctly, ie.: ignition locks, passive arming, passive locks, etc.

Test the doors and hood/trunk inputs (make sure all doors trigger the system, not just the drivers door).

Adjust the shock sensor. (see Real-time Sensor Adjustment Mode)

Arm the system and try starting the vehicle, it should not start.

Arm the system and disarm it with the ignition and valet switch.

If programmed to passively arm make sure that the system arms properly.

Check the range of the remote transmitters.

Tie up wire harness, and replace any under dash panels.

Make sure the customer has physical knowledge of the location of the valet/override switch.

Real-time Sensor Adjustment Mode

This mode allows active testing of the shock sensor and optional sensor input making adjustments without arming the alarm.

To enter Sensor Adjustment mode:

1. Turn the ignition on.
2. Press the Shift Button (Button 5) 3 times, then Button 3.
 - The siren will chirp 4 times, indicating that the sensor is ready to be tested.
3. Test the sensitivity. The siren will chirp a number of times each time a sensor is triggered.
 - One chirp indicates the shock sensor.
 - Two chirps indicates the warn away.
 - Three chirps indicates the optional sensor.
4. To make shock sensor adjustments:
 - Turn the adjustment screw on the sensor clockwise to increase the sensitivity.
 - Turn the adjustment screw on the sensor counter clockwise to decrease the sensitivity.
5. Turn off the ignition when the desired sensitivity level is reached.

RELAY WIRING DIAGRAMS

HORN HONK DIAGRAMS

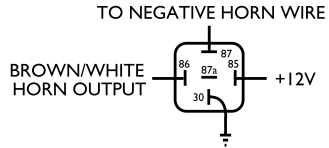
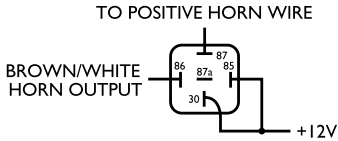

TRUNK RELEASE DIAGRAM

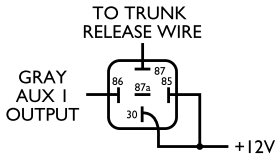

OPTIONAL CIRCUIT DISABLE

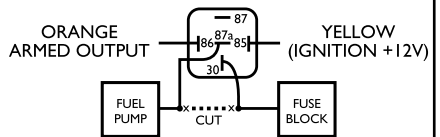

OPTIONAL HEADLIGHT ACTIVATION

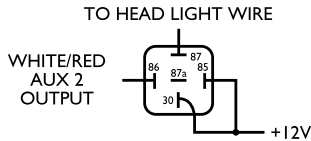

Program the Auxiliary 2 output for timed operation and the headlights will turn on with Aux 2 for the preset timer duration then automatically turn off.

Program the Auxiliary 2 output for latched operation and the headlights will turn on with Aux 2 and remain on until the Auxiliary 2 function is pressed again.

DOOR LOCK WIRING DIAGRAMS

NEGATIVE PULSE LOCK SYSTEM

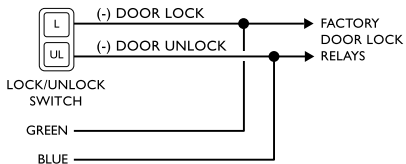

POSITIVE PULSE LOCK SYSTEM

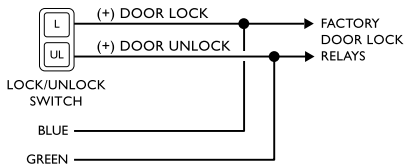

ADDING ACTUATORS

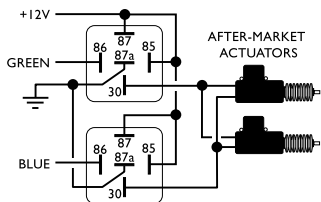

VACUUM LOCK SYSTEM

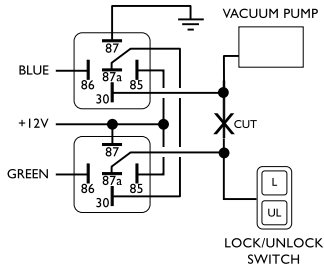

REVERSE POLARITY LOCK SYSTEM

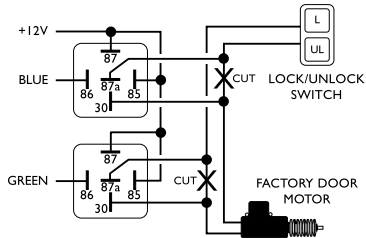

OPTIONAL TWO-STEP UNLOCK WIRING DIAGRAMS

TWO-STEP UNLOCK NEGATIVE PULSE

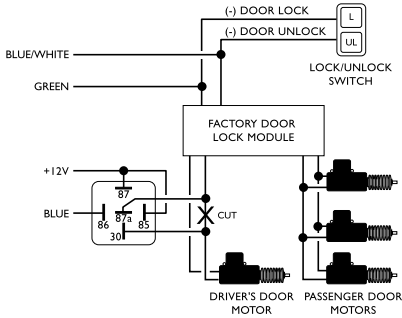

TWO-STEP UNLOCK POSITIVE PULSE

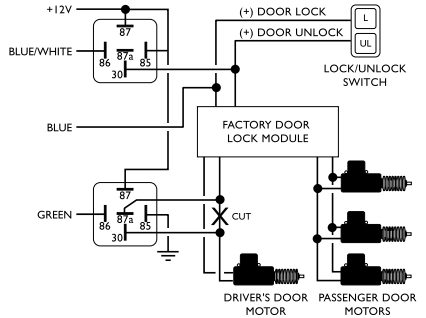

TWO-STEP UNLOCK REVERSE POLARITY

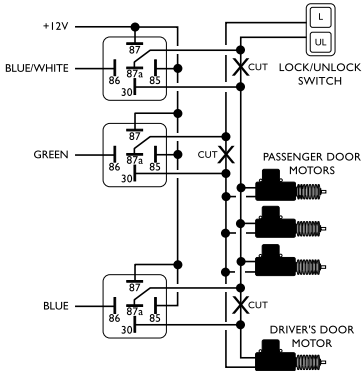

TWO-STEP UNLOCK ADDING ACTUATORS

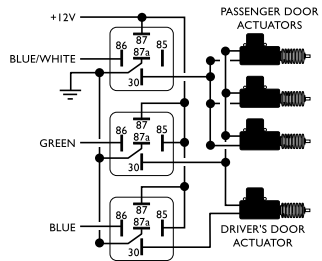

TROUBLESHOOTING

Problem	Probable Cause	Suggested Correction
Alarm does not operate.	Alarm in Valet Mode; Ignition input has voltage on it; Missing +12V or ground.	Take alarm out of Valet mode; Turn key off and verify yellow wire is connected to correct ignition wire; Check +12V and ground connections.
Alarm will not Passively Arm.	Unit is not programmed for Passive Arming, wrong polarity door input wire, Yellow ignition input has 12V+ on it.	Program step #1 for Passive Arming; Correct door switch polarity; Change ignition input wire; Make sure alarm is not in Valet.
Alarm will not enter Code Learning Mode.	Ignition was not left in the on position after turning it on & off three times; Sequence not performed rapidly enough (5 sec.); Valet/Override Switch is defective or not plugged in.	Leave ignition in on position; Repeat procedure quicker; Replace valet switch.
Alarm chirps 4 times 5 seconds after system is Armed.	Factory Dome light Delay is longer than 5 seconds; Door open or defective pin switch; Shock sensor is not properly adjusted or defective.	If dome light delay is longer than 5 seconds program step 10 to OFF; Replace defective pin switch; Adjust or replace shock sensor.
Parking lights do not flash.	Wrong wire connected to the White wire, or requires a negative output.	Connect White wire to the proper vehicle wire, Change jumper polarity of Parking Light relay (see Jumper Settings).
Door locks do not lock/unlock correctly, or action is reversed	Defective GREEN or BLUE wire from door lock connector plug, GREEN and BLUE wires reversed, or wrong door lock wiring diagram used.	Check GREEN and BLUE wires on door lock connector plug. Check vehicle's door lock system for method of operation. Reverse wiring to door relays.
Illuminated Entry does not activate on upon disarm.	Wrong polarity selected.	Change jumper polarity of the Dome Light relay.

TROUBLESHOOTING CONTINUED

Problem	Probable Cause	Suggested Correction
Range is poor.	Antenna wire is grounded; Module is picking up interference from vehicle's electrical system.	Make sure antenna is not grounded; Relocate module or route antenna away from computer modules.
Vehicle starts when armed.	Wrong starter wire was cut. Ignition wire does not have +12V while cranking.	Connect to proper starter wire. Connect YELLOW wire to proper ignition wire
Car will not start when system is disarmed.	Bad connection on brown starter wire harness; Defective starter defeat relay	Repair connection at starter wire; Replace module.
Keyless entry does not operate with remote.	Wrong door lock polarity; Wrong lock wires connected.	See door lock diagram; Verify vehicle lock/unlock wires.
Ignition triggered door lock feature does not operate.	Yellow wire does not show +12V; Door is open; Door trigger input wrong polarity.	Connect YELLOW wire to ignition wire; Close door; Change door trigger polarity.
Car horn honks when system disarmed and door is opened.	Vehicle's factory security system needs to be disarmed.	Locate disarm wire (usually located in drivers kick panel) and use unlock pulse to disarm factory system.
Car will not start and alarm does not function properly.	Vehicle battery dead or drops below 9 volts when trying to start the vehicle.	Charge or replace battery.

LED INDICATIONS

On Solid = Valet Mode
 Slow Flash = System Armed
 Rapid Flash = Passive Arming
 2 Flashes = Shock Sensor
 4 Flashes = Door Trigger
 5 Flashes = Hood/Trunk

LED TAMPER ALERT INDICATIONS

1 Flash = Optional Sensor
 2 Flashes = Shock Sensor
 4 Flashes = Door Trigger
 5 Flashes = Hood/Trunk

PARKING LIGHTS FUNCTIONS

Flash 1x = Doors Locked
 Flash 2x = Doors Unlocked
 Flash 3x = Open Zone
 Indication (after arming)
 Flash 3x after Disarm =
 Tamper Alert

WIRING DIAGRAM

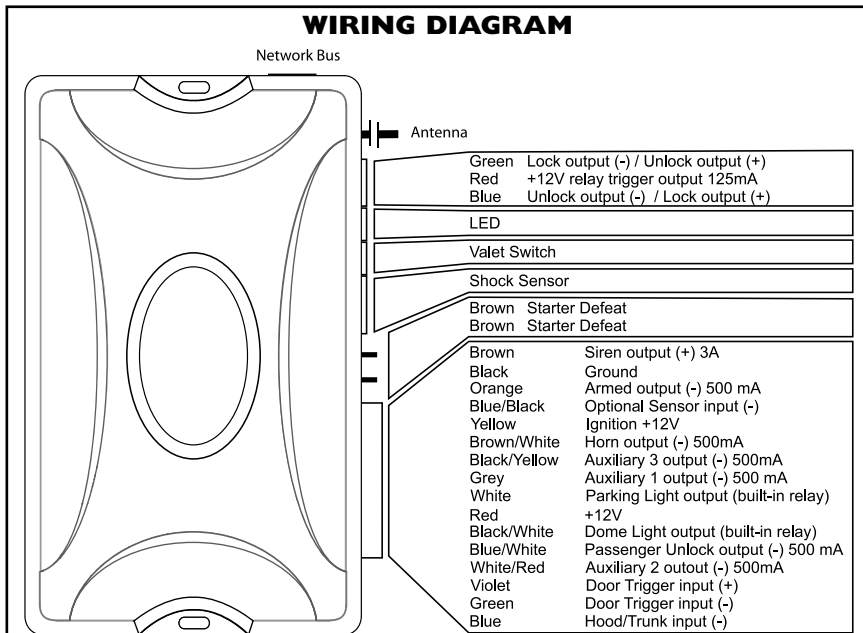

JUMPER SETTINGS

The output polarity for the built-in parking light and dome light relays is determined by the placement of the jumper on the 3 pins next to each relay. The default settings are illustrated below.

Jumper on Center Pin and Left Pin = Positive Output
 Jumper on Center Pin and Right Pin = Negative Output

